

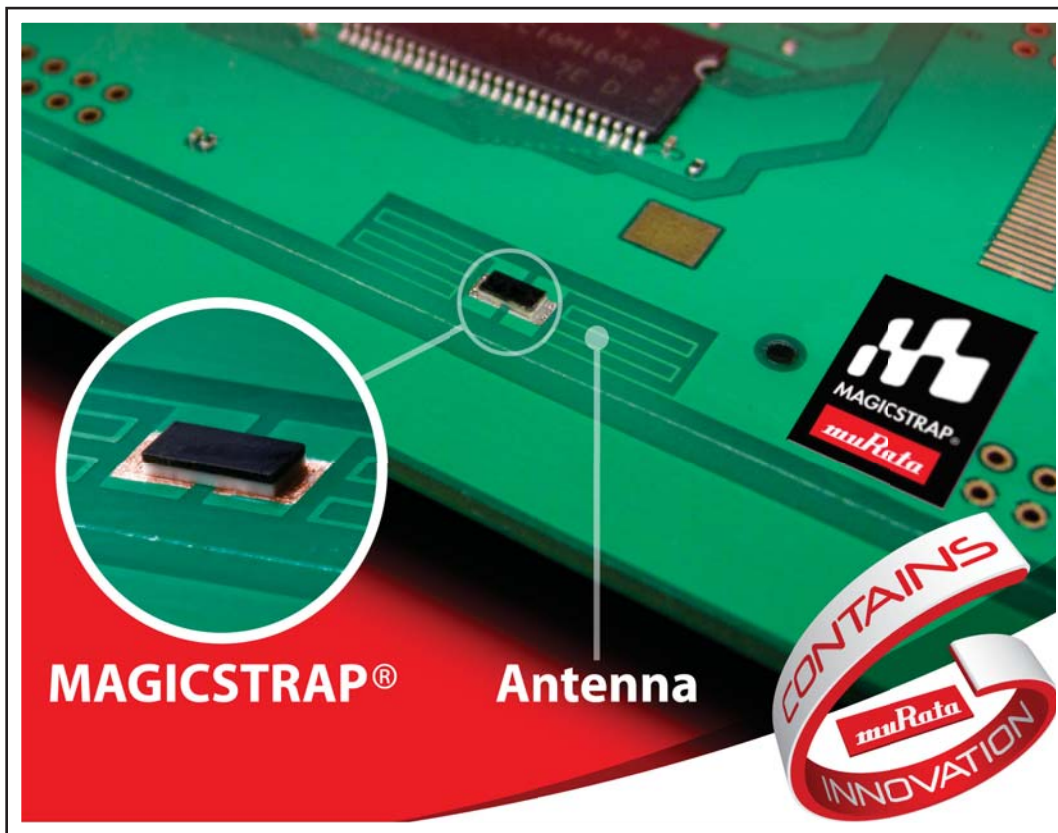

Printed Circuit Board RFID Devices

LXMS Series



Murata’s MAGICSTRAP® is the latest in UHF RFID chip development, designed to be placed on the printed circuit board (PCB). The integrated module eliminates many of the frustrations previously encountered by design engineers looking to incorporate RFID into their project.

By following some basic and simple guidelines, the antenna is designed into the PCB’s ground plane. This represents a permanent and cost effective antenna solution. Once mounted, information can be stored and retrieved on MAGICSTRAP® using any EPCglobal Gen2 / ISO 18000-6C compatible UHF Reader/Writer.

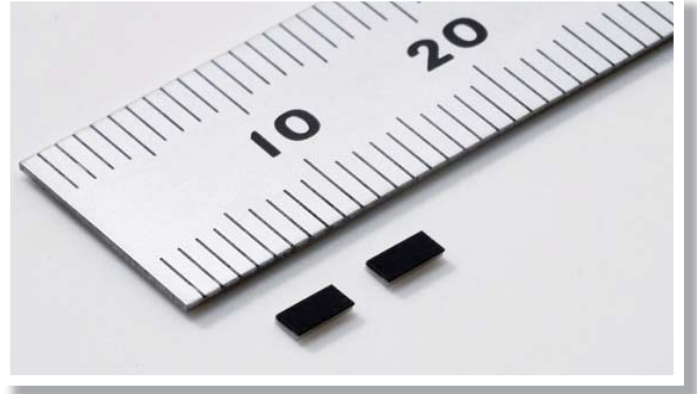

Features

- Compact Size (3.2 x 1.6 x 0.7mm)
- Operating Frequency – 860-960MHz
- 512 bits user memory
- EPC Global Gen2 / ISO 18000-6C compatible
- Secure with long data retention
- 4 to 5 meter read range is possible
- Utilizes ground as PCB ground as antenna
- Reference antenna designs available
- ESD protection up to >2kV
- Fully RoHS compliant

MAGICSTRAP® Use Cases



MAGICSTRAP®

PCB Traceability

Warranty Tracking

Inventory Control

Product Authenticity

Firmware Revision Tracking

Applications

- IT – PC, Server, Modem, Mobile phone
- Consumer – STB, DTV, DVD, audio
- Automotive – instrument panel, audio...
- Industry – smart meters, inverters
- Home appliances – stove, refrigerator
- EMS – value added services
- Specialty applications – durable tags
- Gaming – portable, stationary

Product Lineup

Part Number	Type *	IC	EPC	User Memory	TID	Op Temp
LXMS31ACNA-009	1	NXP G2XM	up to 240 bits	512 bits	64 bits	-40°C to +85°C
LXMS31ACNA-010	2					
LXMS31ACNA-011	3					
LXMS31ACNA-012	4					
LXMS31ACMD-141	1	Impinj Monza4QT	up to 128 bits	512 bits	64 bits	
LXMS31ACMD-142	2					
LXMS31ACMD-143	3					
LXMS31ACMD-144	4					

* Type refers to the impedance value and recommended antenna reference design

Part Number Breakdown

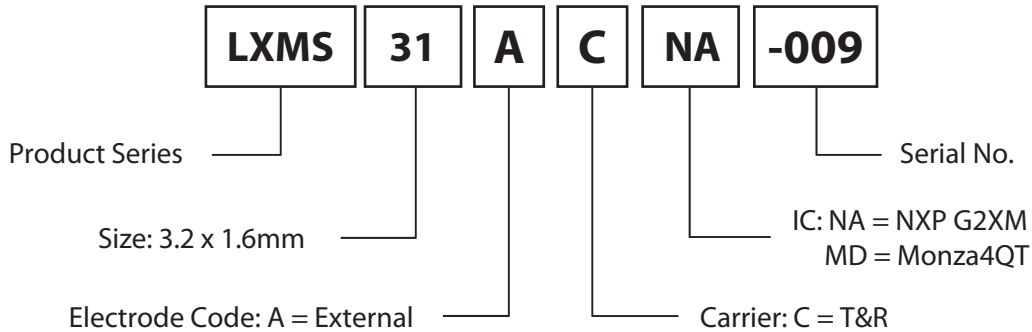

Dimensions (mm)

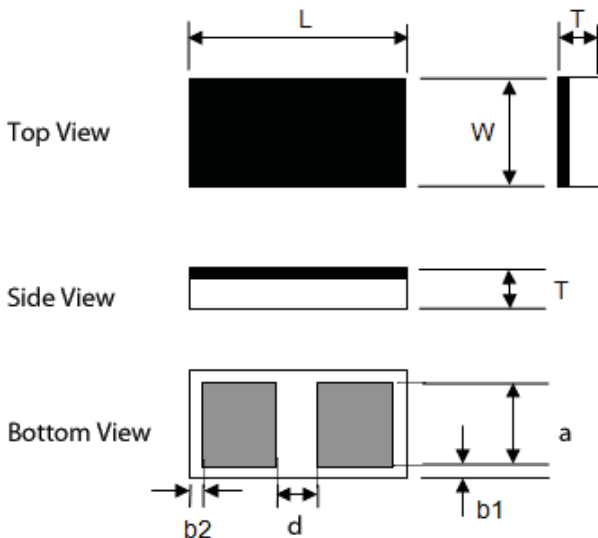

Mark	Dimensions	Mark	Dimensions
L	3.2 ± 0.2	b1	0.18 ± 0.18
W	1.6 ± 0.2	b2	0.18 ± 0.18
T	0.7 max.	d	0.7 ± 0.1
a	1.25 ± 0.1	-	-

MAGICSTRAP® Block Diagram

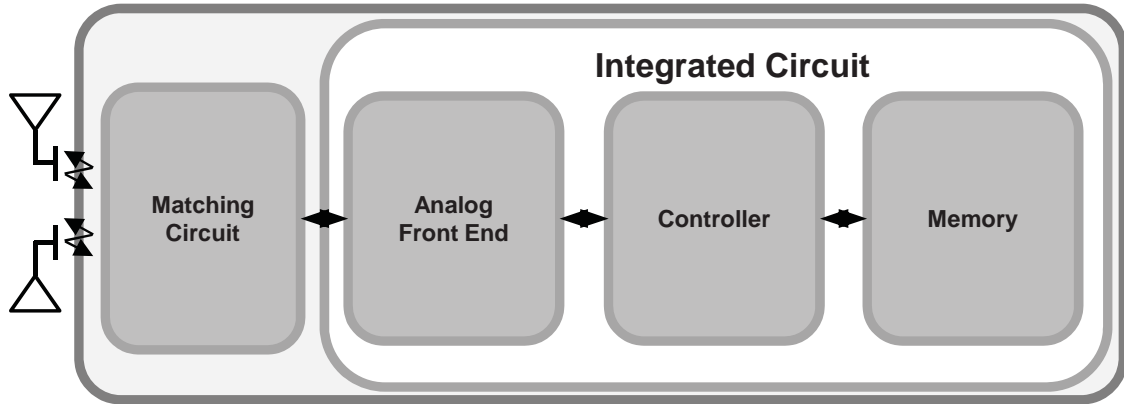

Recommended Land Pattern Design

Recommended land pattern
(SMT process)

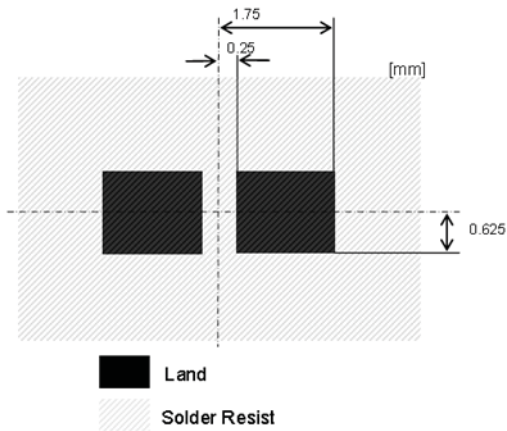

Recommended land pattern
(adhesive attachment)

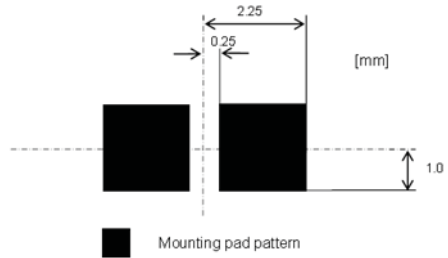

Electrical Parameters

- Frequency Range: 865 – 955MHz
- Minimum operating power: -8dBm
- Electrical characteristics at minimum operating power ($T_a=25^{\circ}C$, unit: Ω)

Parameter			MAGICSTRAP® P/N	LXMS31ACNA-009 LXMS31ACMD-141	LXMS31ACNA-010 LXMS31ACMD-142	LXMS31ACNA-011 LXMS31ACMD-143	LXMS31ACNA-012 LXMS31ACMD-144
			Impedance Value	@866.6MHz	R	15	12
X	-45	-107			-200	-405	
@915.0MHz	R	25		12	25	80	
	X	-45		-107	-200	-420	
@953.0MHz	R	30		9	20	60	
	X	-48		-105	-195	-425	

Read Range

4W EIRP @ 915MHz

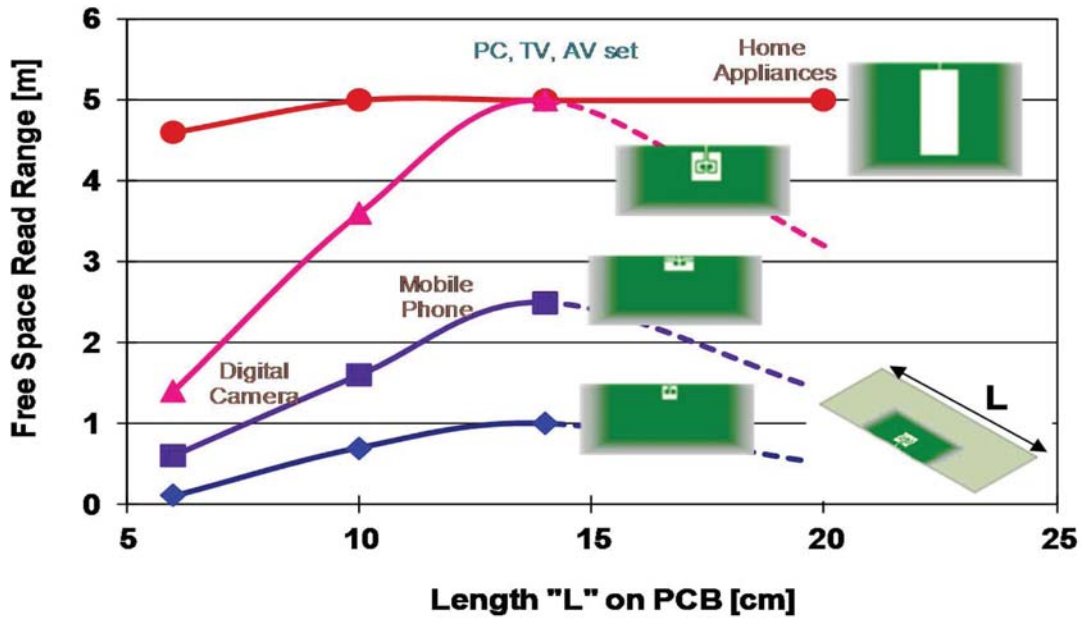

Note: distances measured with 4W EIRP reader, 6dBi circularly polarized antenna, at 915 MHz; MAGICSTRAP® using NXP G2XL/M.

Reference Antenna Design and Performance

Type 1

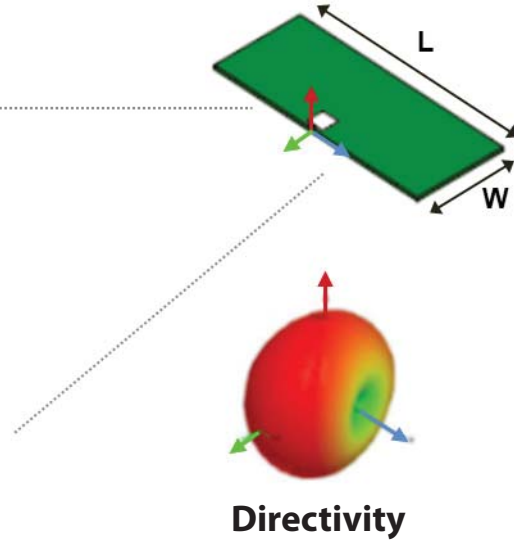
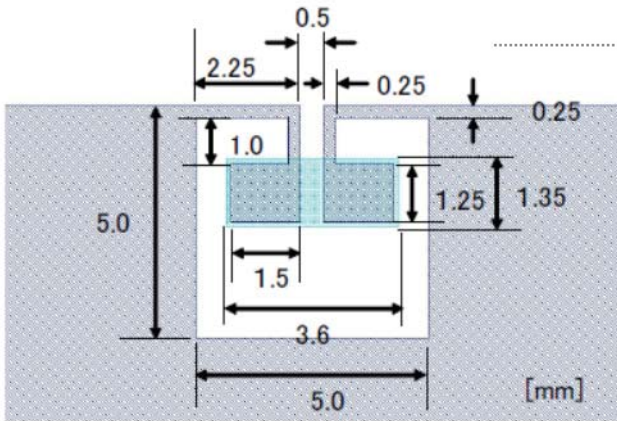

Actual Read Range

PCB Size L x W	USA (m)	Japan (m)
20 x 6cm	0.5	0.4
14 x 4cm	1.0	0.8
10 x 4cm	0.7	0.5
6 x 4cm	0.1	0.1

30dBm, 6dB1 (4W EIRP) w/circularly polarized wave

*Reader/Writer: CSL-461

** 2mm read range is available with loop antenna

PCB Size L x W	USA (cm)	Japan (cm)
20 x 6cm	3.0	1.0
14 x 4cm	10.0	0.8
10 x 4cm	**	**
6 x 4cm	**	**

10dBm, 6dB1 (40mW EIRP) w/linearly polarized wave

Read Range (m) by Freq (MHz)

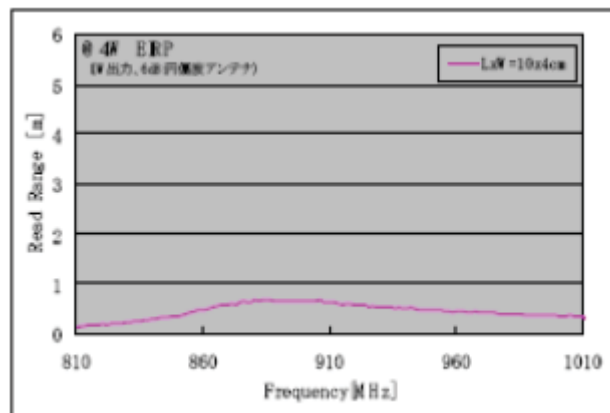

Simulation according to min. operating power

Reference Antenna Design and Performance

Type 2

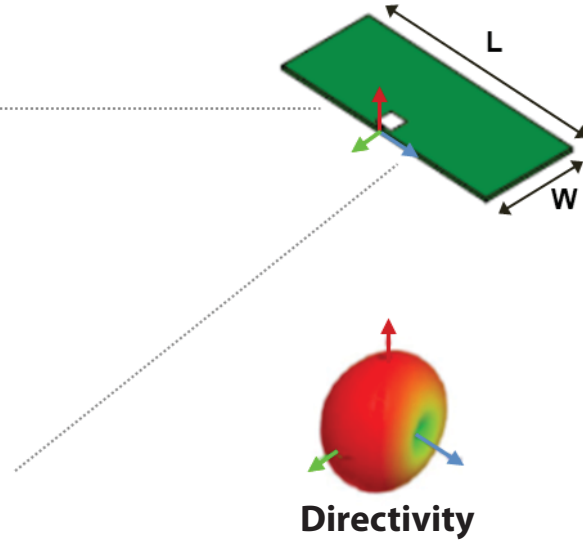
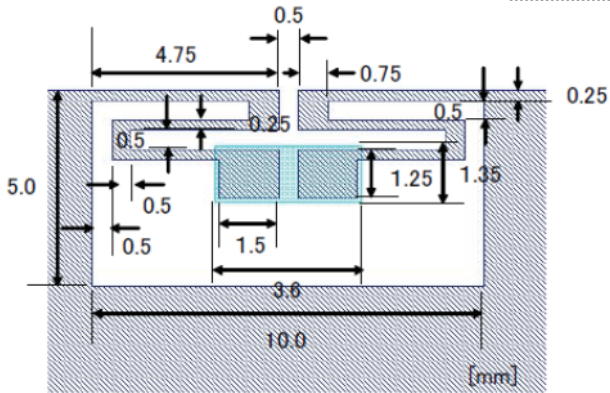

Actual Read Range

PCB Size L x W	USA (m)	Japan (m)
20 x 6cm	1.4	1.1
14 x 4cm	2.5	2.0
10 x 4cm	1.6	1.6
6 x 4cm	0.6	0.5

30dBm, 6dB1 (4W EIRP) w/circularly polarized wave

*Reader/Writer: CSL-461

** 2mm read range is available with loop antenna

PCB Size L x W	USA (cm)	Japan (cm)
20 x 6cm	5	3
14 x 4cm	20	10
10 x 4cm	5	10
6 x 4cm	**	**

10dBm, 6dB1 (40mW EIRP) w/linearly polarized wave

Read Range (m) by Freq (MHz)

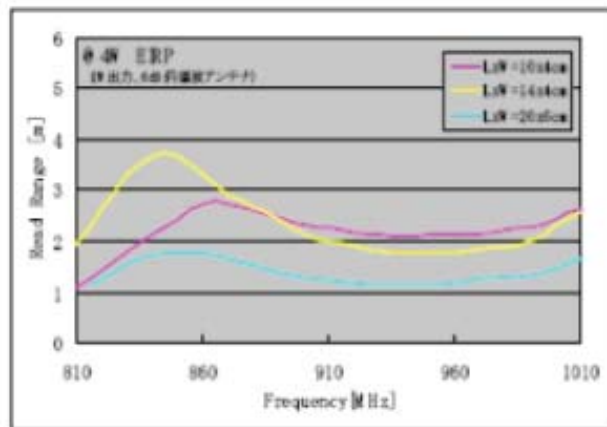

Simulation according to min. operating power

Reference Antenna Design and Performance

Type 3

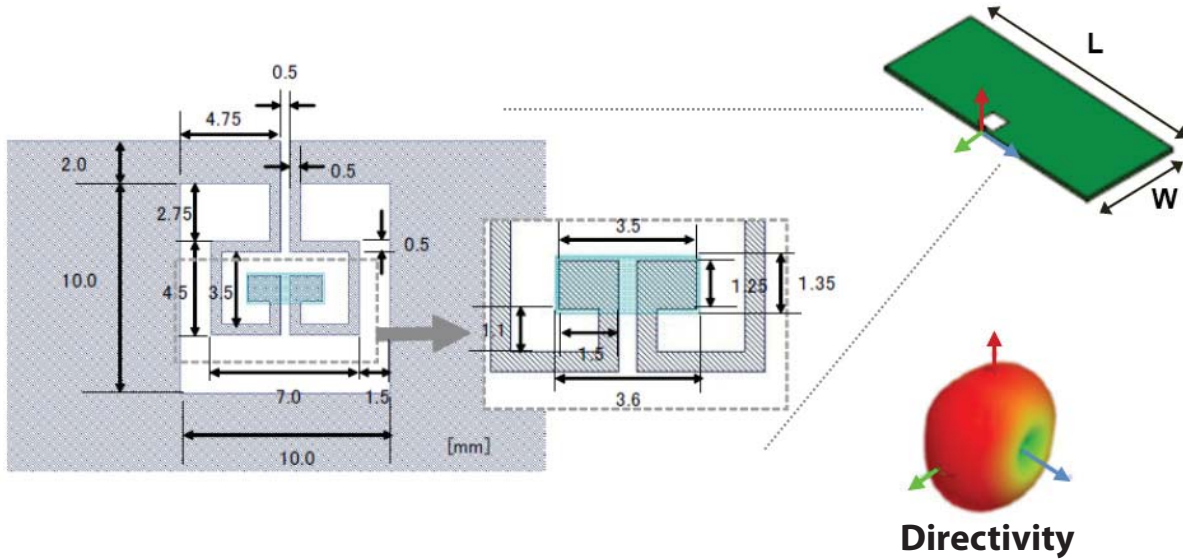

Actual Read Range

PCB Size L x W	USA (m)	Japan (m)
20 x 6cm	3.2	2.6
14 x 4cm	5.0	4.3
10 x 4cm	3.6	3.6
6 x 4cm	1.4	1.4

30dBm, 6dB1 (4W EIRP) w/circularly polarized wave

*Reader/Writer: CSL-461

** 2mm read range is available with loop antenna

PCB Size L x W	USA (cm)	Japan (cm)
20 x 6cm	40	30
14 x 4cm	60	45
10 x 4cm	40	30
6 x 4cm	15	15

10dBm, 6dB1 (40mW EIRP) w/linearly polarized wave

Read Range (m) by Freq (MHz)

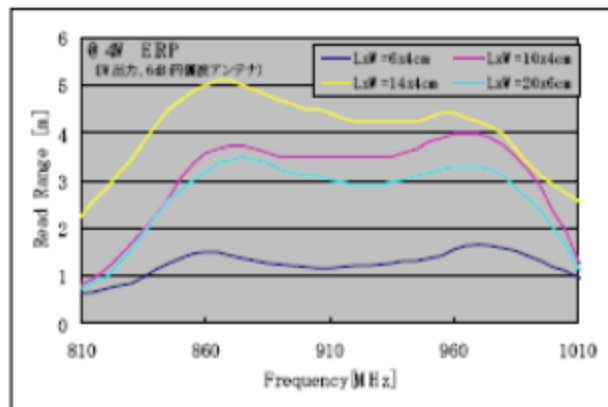

Simulation according to min. operating power

Reference Antenna Design and Performance

Type 4

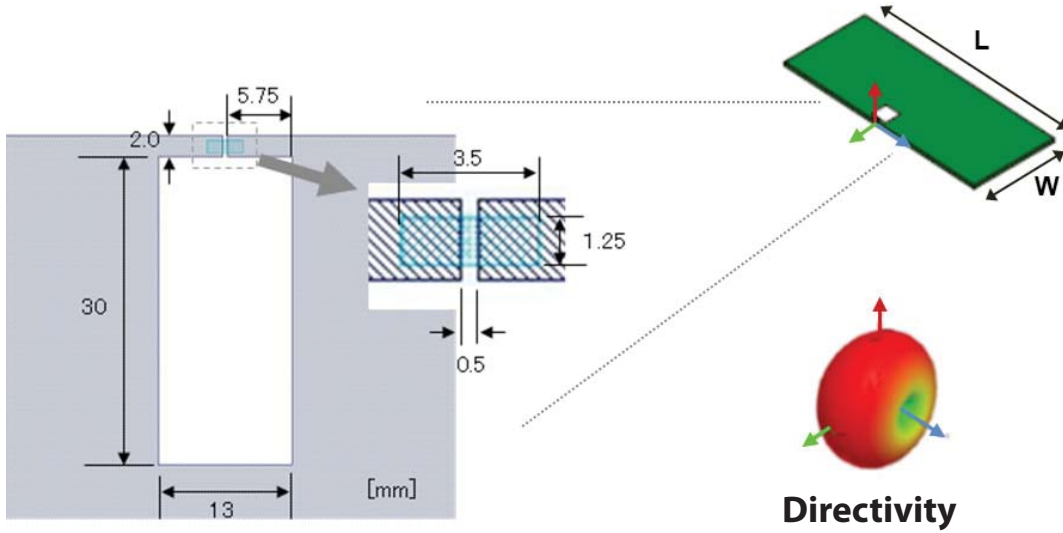

Actual Read Range

PCB Size L x W	USA (m)	Japan (m)
20 x 6 cm	5.0	3.0
14 x 4cm	5.0	3.0
10 x 4cm	5.0	3.0
6 x 4cm	4.6	3.5

30dBm, 6dB1 (4W EIRP) w/circularly polarized wave

*Reader/Writer: CSL-461

** 2mm read range is available with loop antenna

PCB Size L x W	USA (cm)	Japan (cm)
20 x 6cm	40	20
14 x 4cm	45	30
10 x 4cm	50	30
6 x 4cm	50	40

10dBm, 6dB1 (40mW EIRP) w/linearly polarized wave

Read Range (m) by Freq (MHz)

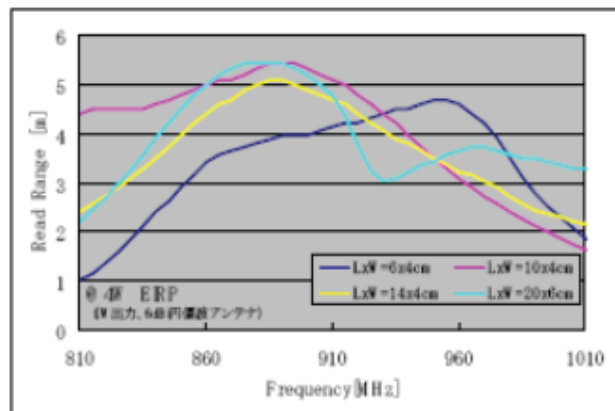

Simulation according to min. operating power

PCB Design Rules to Maximize Read Range

1 – Position of MAGICSTRAP® on PCB:

MAGICSTRAP® should be centered on the long side of the PCB to maximize read range. The following illustrates the relationship between “X” length and read range using Type-3 board design.

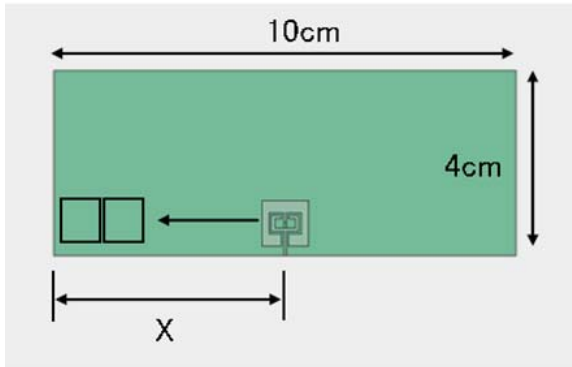

Length “X” (cm)	Read Range (m)
5	3.6
2	2.5
1	1.6

2 – Eliminate conductive material under MAGICSTRAP®:

All layers beneath MAGICSTRAP® should be free of conductive material. This area should be equal or larger than the top layer antenna design to maximize read range. The example below is using Type 3 design.

Top PCB Layer (antenna interface)



Other Layers

Acceptable board designs

Unacceptable board designs

PCB Design Rules to Maximize Read Range

3 – Metal enclosure under printed circuit board:

When the PCB is in close proximity to the metal enclosure, sensitivity is reduced. Removing material directly under the MAGICSTRAP® antenna pattern will greatly improve sensitivity.

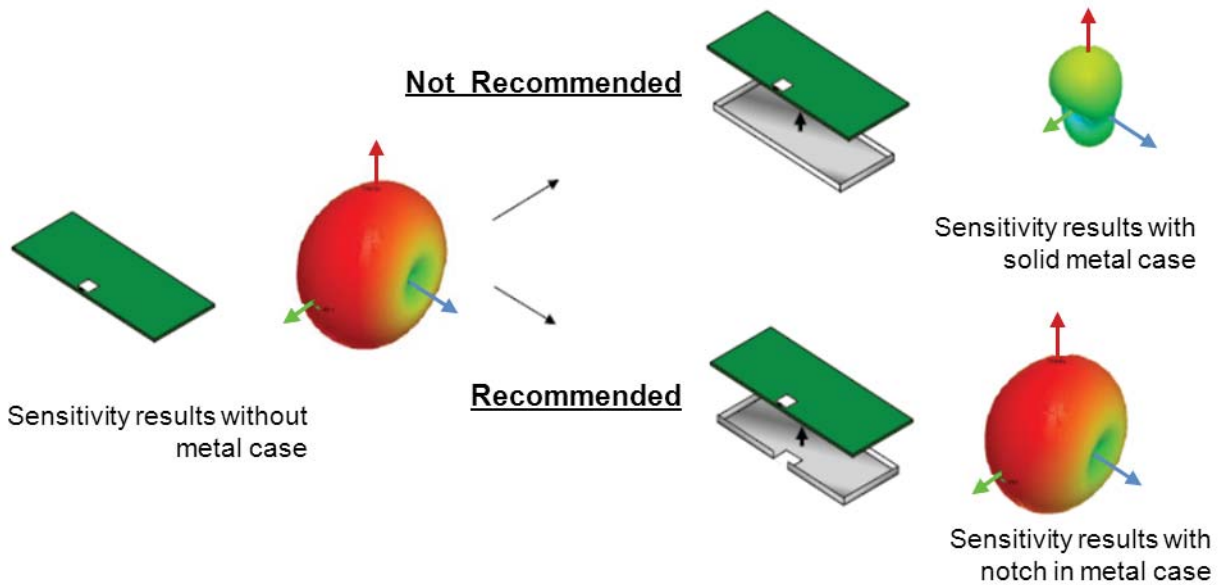

4 – Antenna location on PCB

Location of the PCB antenna should be located closest to the edge of the PCB, as shown below in dark green. Variations of ideal design are also acceptable.

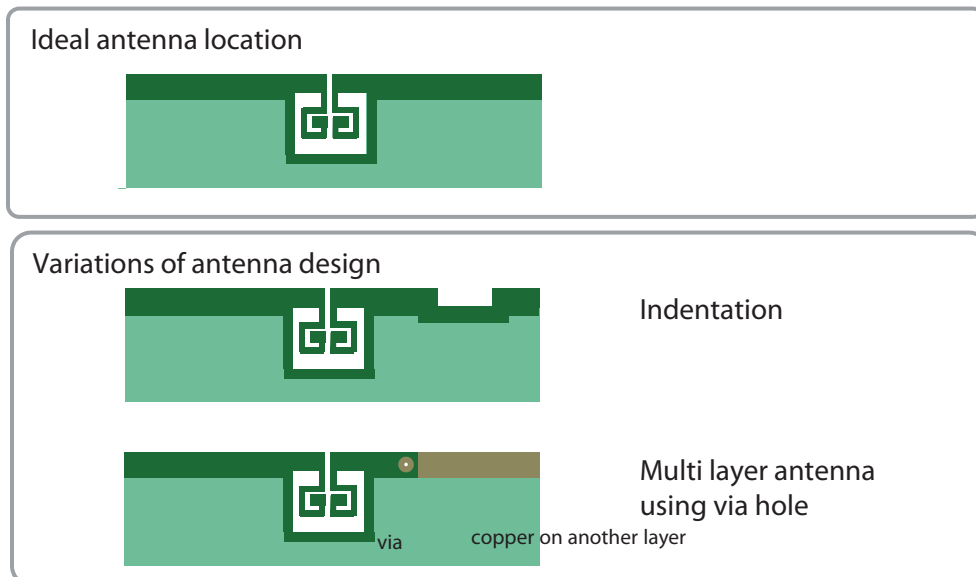

Prototyping using MAGICSTRAP®

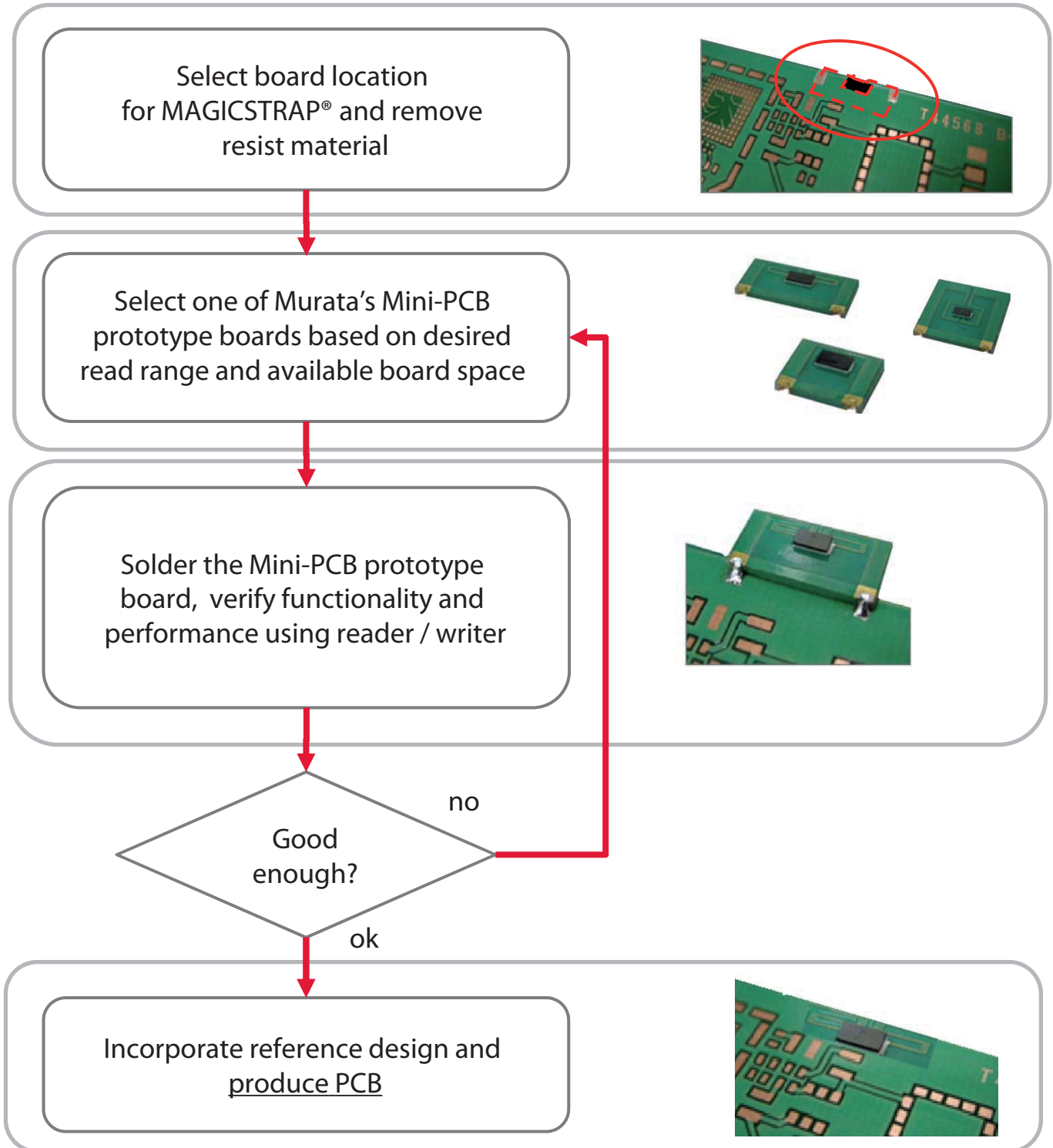

muRata

Innovator in Electronics

muRata Murata Manufacturing Co., Ltd.

Head Office

1-10-1, Higashi Kotari 1-chome
Nagaokakyo-shi, Kyoto
617-8555, Japan
Phone: 81-75-951-9111

International Division

3-29-12, Shibuya 3-chome,
Shibuya-ku, Tokyo
150-0002 Japan
Phone: 81-3-5469-6123

Murata Americas

Murata Electronics N.A., Inc. (Regional HQ)
2200 Lake Park Drive
Smyrna, GA 30080-7604, USA.
Phone: 1-770-436-1300
Fax: 1-770-436-3030

For additional information visit:
www.murataamericas.com/rfid

Murata (China) Investment Co., Ltd.

Lane 318 Yonghe Road
Zhabei District, Shanghai 200072, China
Phone: 86-21-3205-4616
Fax: 86-21-3205-4617

Murata Europe

Murata Electronics Europe B.V. (Regional HQ)
Daalmeerstraat 4, 2131HC Hoofddorp
The Netherlands
Phone: +31-(0)23-5698360
Fax: +31-(0)23-5698361

Taiwan Murata Electronics Co., Ltd.

No 225 Chung - Chin Road, Taichung, Taiwan
Phone: 886-4-2425-4151

Murata Electronics Singapore (Pte.) Ltd.

200 Yishun Avenue 7
Singapore, 768927
Tel: 65-6758-4233
Fax: 65-6758-2026

